

# Recycling Bins

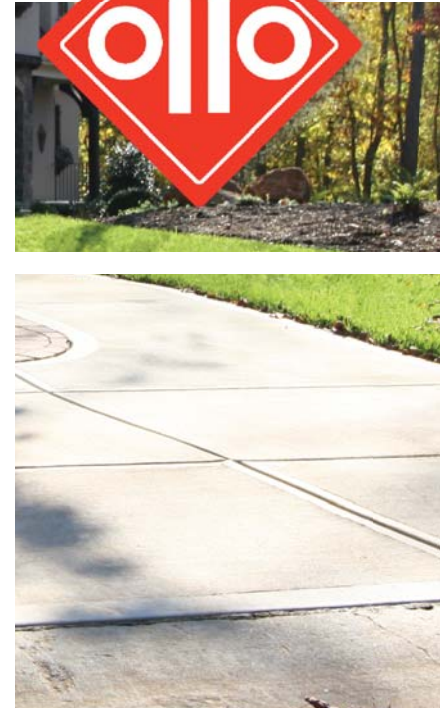

## ▼ User Friendly Bin For Recycling Programs

- Allows for commingled or separated collection of recyclables
- Designed to withstand rough handling and extreme weather conditions
- Optional 18 gallon lid fits securely over bin's rim
- Unique nesting design reduces distribution costs and makes containers convenient to stack and store
- Large graphic area available to place company, community, or program logo
- Available in a variety of colors to fit your program's specific requirements



Optional lid is available for 18 gallon

# Recycling Bins - 14 and 18 Gallon

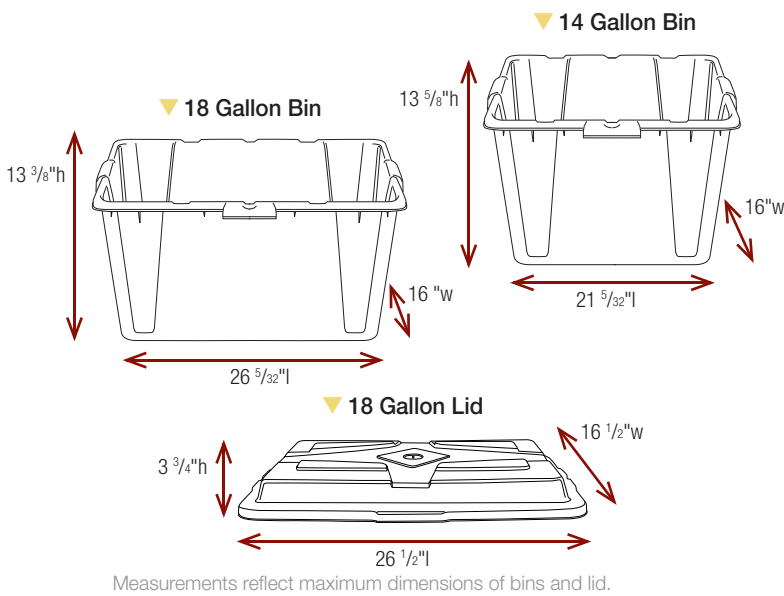

## ▼ Available Colors

The Recycling Bins are available in 14 standard colors. The standard lid color is black to coordinate with bins. Custom colors available upon request in both the bin and lid.



Dark Blue - 68 Cobalt - 75 Black - 60 Dark Gray - 50 Forest Green - 65 Kelly Green - 78 Red - 66



Light Blue - 51 Sky Blue - 77 Brown - 63 Light Gray - 57 Green - 56 Orange - 59 Yellow - 72

Colors as shown in this document may differ slightly from the actual product.

## ▼ Bin Features

- Ergonomic handle design
- Contains recycled post-consumer, high density polyethylene
- Available with or without drain holes

## ▼ Customize Your Bin

- Hot stamp sides of bin with company logo or message
- RFID Tag or Barcode available



## ▼ Bin Specifications

MODEL	HEIGHT	LENGTH	WIDTH
18 GAL.	13 3/8"	26 5/32"	16"
18 GAL. LID	3 3/4"	26 1/2"	16 1/2"
14 GAL.	13 5/8"	21 5/32"	16"

Bin specifications vary slightly based on product mold.

## ▼ 18 Gallon Lid Features And Benefits

- Flexible handles with latch for easy release and fastening
- Corrugated lid for strength, keeps its shape
- Injection molded, composed of high density polyethylene
- Bin nests in inverted lid
- Keeps recyclable items dry while out for collection, deters insects and pests
- Prevents odors, great in highly populated areas or in warm, humid climates
- Recyclables remain contained during inclement weather such as strong winds
- Standard color is black, available in custom colors for an additional cost



Lid latch, along with matching curves, fastens lid securely to bin

## ▼ Shipping Information

MODEL	ASSEMBLY WEIGHT	UNITS PER PALLET	T/L QTY (53' TRUCK)	LTL UNITS PER PALLET	LTL MAX. QTY
18 GAL.	5 LBS.	200 PER PALLET	5000	200 PER PALLET	N/A
18 GAL. LID	N/A	400 PER PALLET	11200	300 PER PALLET	4 Skids
14 GAL.	4.2 LBS.	200 PER PALLET	5000	200 PER PALLET	N/A

Shipping information is estimated. Alterations to specifications may occur.

